

# SERIES 1400 3-1/4" SINGLE INSWING TERRACE DOOR (C70)

## SPECIFICATIONS

### I. GENERAL:

Scope of Work - Furnish all necessary materials, labor and equipment for the complete installation of aluminum hinged glass doors for this project as shown on the drawings and herein specified. Doors shall be the "Series 1400" as manufactured by Thermal Windows, Inc., Tulsa, Oklahoma. The "Series 1400" is a single vent Hinged Glass Door with thermally improved main frame and vent consisting of side hinges, locking handle and multipoint lock system. The specifications and materials for the "Series 1400" are as follows:

### II. PRODUCTS:

Materials - Aluminum shall be of proper alloy for commercial window construction. All extruded sections shall be of 6063-T5 aluminum alloy.

Frame - Main frame and sash members shall be a .062" nominal thickness. Main frame shall be 3.25" in depth. Horizontal and vertical vent members shall be hollow extrusions. Main frames and vent members are to be extruded aluminum with a dual insulbar thermal barrier system creating a 5/8" wide thermal barrier.

Hardware - Operating handle shall be lever type connecting to a multi-point lock system. Lock system engagements shall be as follows: Two (2) at handle, one (1) 2 1/2" from each end of lock stile and one (1) centered between handle and upper locking point. Lock cannot be operated from exterior. One (1) friction catch shall be located on vent and frame to hold door closed when handle is in unlocked position. Door shall also be fitted with one (1) field adjustable limit device at head to restrict door panel travel. Limit device shall also utilize a friction adjusting screw.

Hinges - Shall consist of four (4) extruded aluminum butt type hinges. Hinge pins shall be 1/4" diameter stainless steel with hard vinyl bushings.

Weatherstripping - Door panel shall close to a full perimeter EPDM weatherseal utilizing welded corner construction.

### III. CONSTRUCTION:

Assembly - Main frame and door panel corners shall be of mitered, sealed, crimped and staked corner construction. Each corner shall consist of one extruded aluminum corner key held in place with two die cast retainer pins, one die cast corner key staked in place and one friction fit hard vinyl corner key.

Glazing - Glass in the door panel shall be factory glazed using EPDM gasket at exterior perimeter with extruded aluminum glazing bead and EPDM wedge at interior of glass. The insulated glass units shall be 1" overall thickness with two panes .125" tempered glass, separated by a .750" air space for optimum insulation. All insulated glass units shall meet the requirements of the ASTM E 774 specification, Class "A".

Finish - Shall be a factory applied baked polyurethane powder coat finish meeting the requirements of AAMA 2603 for Pigmented Organic Coating on Extruded Aluminum. Refer to "Colors and Finishes" chart for examples. Bronze anodizing, clear anodizing and high performance AAMA 2605 finishes are optional.

Operation - The door panel is operable to the inside and lockable from the inside. Friction catch and pull handle allow the door panel to be held closed and operated from the outside.

### IV. PERFORMANCE:

Structural Performance - Shall meet the requirements of ANSI/AAMA 101/I.S.2-97, HGD-C70 specification. Optional Fair Housing threshold: HGD-C40.

### V. INSTALLATION:

Qualifications - Installation shall be performed by skilled, experienced tradesmen. Units shall be installed plumb, level, square and shall be secured in accordance with detailed shop drawings. A non-hardening sealant compatible with aluminum shall be provided by the installer and applied in sufficient quantity to provide a weathertight seal between the window and surrounding construction.

Installation Details - The door manufacturer shall submit complete installation details for the Architects approval. The drawings shall show elevations of windows, full size details of frame and vents, details of construction and anchorage of window.

# SERIES 1400 3-1/4" SINGLE INSWING TERRACE DOOR

Typical Configurations (Scale: Half size)

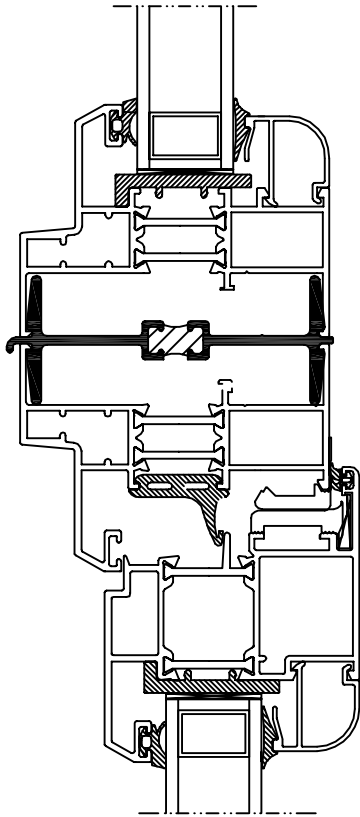

A

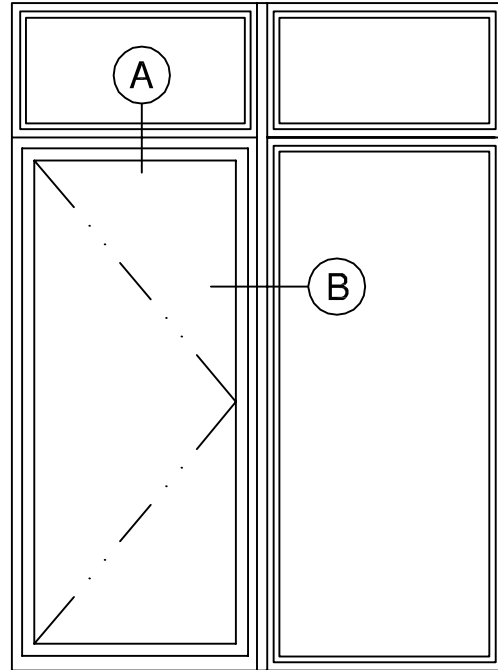

B

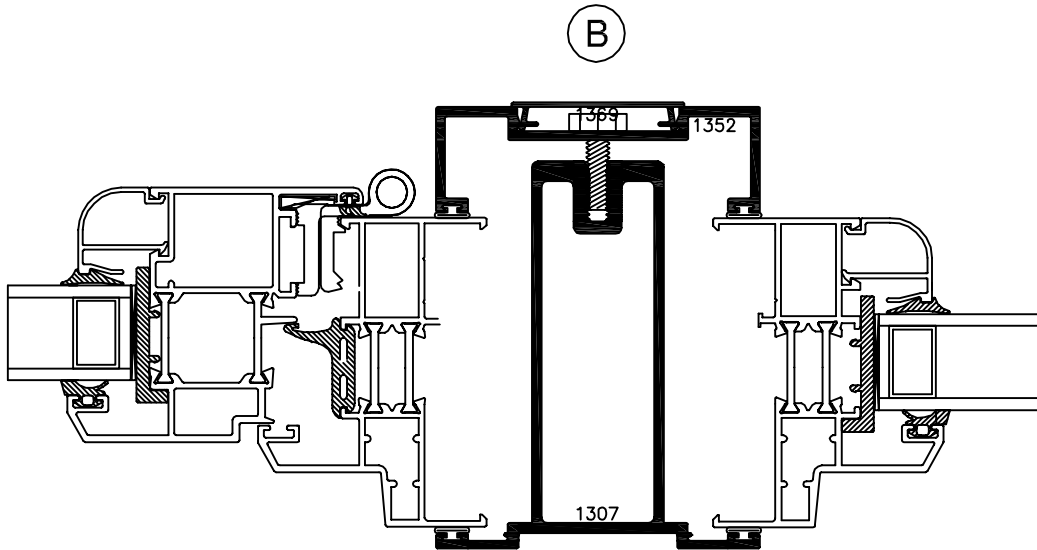

# SERIES 1400 3-1/4" SINGLE INSWING TERRACE DOOR

Product Details (Scale: Half size)

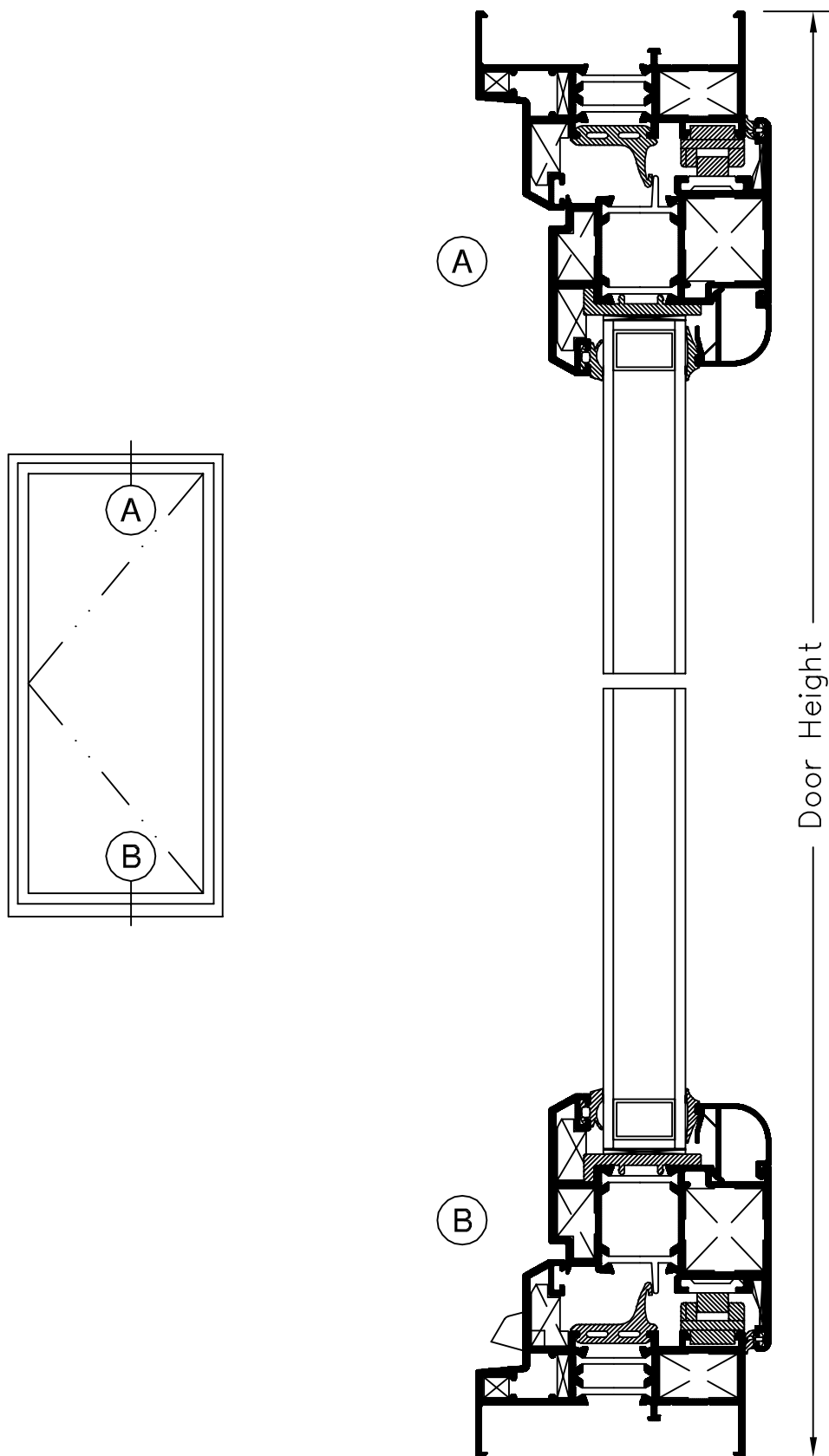

# SERIES 1400 3-1/4" SINGLE INSWING TERRACE DOOR

Product Details (Scale: Half size)

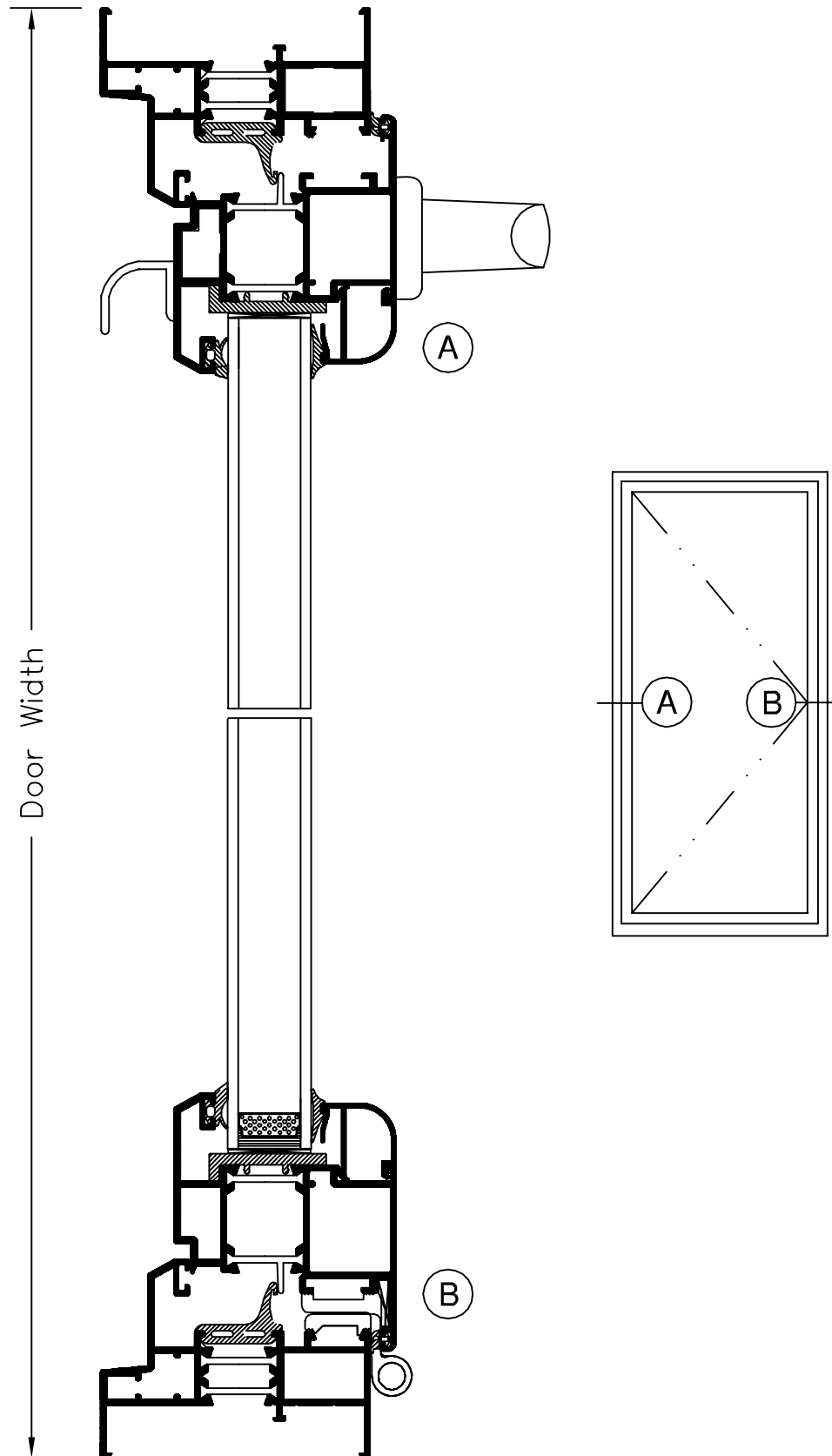

# SERIES 1400F 3-1/4" SINGLE INSWING TERRACE DOOR

With Fair Housing sill

Product Details (Scale: Half size)

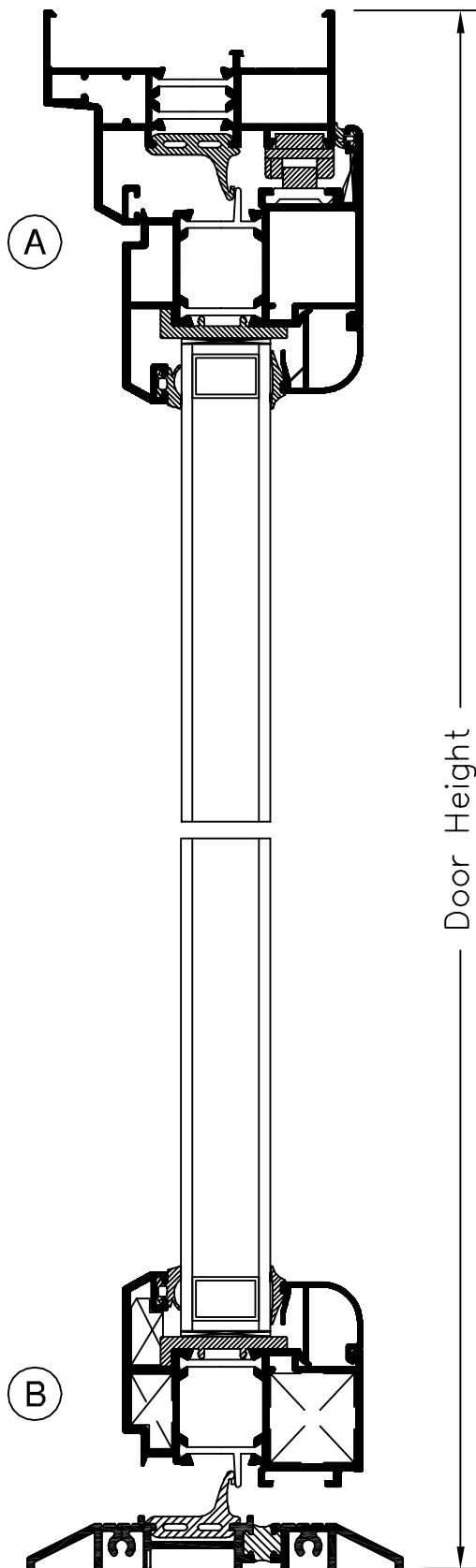
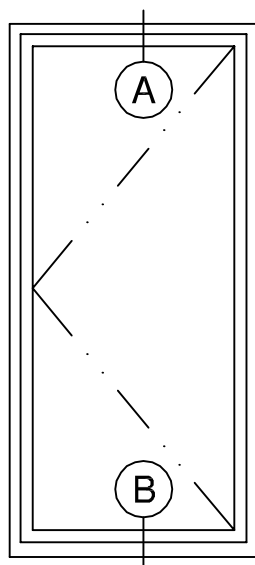

# SERIES 1400F 3-1/4" SINGLE INSWING TERRACE DOOR

Product Details (Scale: Half size)

With Fair Housing sill

