

SERIES 4125HD 4" HORIZONTAL ROLLING (AW60 / IMPACT)

SPECIFICATIONS

I. GENERAL: Impact Test - Double Glazed

Scope of Work - Furnish all necessary materials, labor and equipment for the complete installation of aluminum windows for this project as shown on the drawings and herein specified. Windows shall be the "Series 4125HD" as manufactured by Thermal Windows, Inc., Tulsa, Oklahoma. The "Series 4125HD" is a horizontal double slider with thermally improved frame and sash consisting of two operable, removable and sliding sash. The specifications and materials for the "Series 4125HD" are as follows:

II. PRODUCTS:

Materials - Aluminum shall be of proper alloy for commercial window construction. All extruded sections shall be of 6063-T5 aluminum alloy.

Frame - Main frame and sash members shall be a nominal thickness as required by ANSI/AAMA 101. Main frame shall be 4.000" in depth. Vertical sash members shall be hollow extrusions. Main frames and sash members are to be extruded aluminum with a structural thermal barrier of high density low thermal conductivity polyurethane, poured and debridged.

Locks - Shall consist of a cam latch at the interlocking meeting rail along with two independent spring loaded latch for each sash.

Weatherstripping - Shall be .250 polypile with mylar fins conforming to AAMA 701.2, Specification for Pile Weatherstrip. Weatherstripping shall be doubled at all points of contact of the sash and main frames and at the interlocking meeting rail.

III. CONSTRUCTION:

Assembly - Main frame shall be a mechanically joined construction. Corner joints should be "seam sealed" with a quality grade of sealant meeting the requirements of AAMA 803.3. The sashes shall be assembled with two screws at each corner. All screws at joints of sash and main frame shall be secured into integral screw ports.

Glazing - Glass shall be factory glazed with an interior extruded aluminum glazing bead with a vinyl wedge gasket. The insulated glass units shall be 1.000" overall thickness with two panes of glass, separated by an air space. The glazing shall be in accordance with actual impact testing options. Glazing options include Insulated Glass Units with Polycarbonate Interlayer.

Screens - Screen frame shall be of hollow extruded aluminum frames. Finish shall match the main frames and sash. Insect screening shall be fiberglass or aluminum wire secured with a vinyl spline. Screens shall be full length.

Finish - Shall be a factory applied baked polyurethane powder coat finish meeting the requirements of AAMA 2603/4 for Pigmented Organic Coating on Extruded Aluminum. Refer to "Colors and Finishes" chart for examples. Bronze anodizing, clear anodizing and high performance AAMA 2605 finishes are optional.

Operation - The "X" sashes are operable on the "Series 4125" horizontal double slider window and will slide open for ventilation. Both sashes roll on two non-adjustable, bronze roller bearings and are removable from the interior for ease of maintenance.

IV. PERFORMANCE:

Structural - Shall meet the requirements of ANSI/AAMA 101/I.S. 2-97; HS-AW60 specification.

Thermal - Shall meet the requirements of AAMA 1503.1-88.

NFRC - Shall meet the requirements of NFRC 100-97 and 200.

Forced Entry - Shall meet the requirements for AAMA 1302.5-76 and ASTM F588 Load Identification Level 10.

Life Cycle - Product meets the criteria including passing air and water tests at the conclusion of the cycle test requirements of AAMA 101 and AAMA 910.

Sound Transmission Class - Shall meet the requirements of ASTM E90. Ratings vary depending upon glazing. See Product Selection Guide for summary.

V. INSTALLATION:

Qualifications - Installation shall be performed by skilled, experienced tradesmen. Units shall be installed plumb, level, square and shall be secured in accordance with detailed shop drawings. A non-hardening sealant compatible with aluminum shall be provided by the installer and applied in sufficient quantity to provide a weathertight seal between the window and surrounding construction. All in accordance with actual test methods.

Installation Details - The window manufacturer shall submit complete installation details for the Architects approval. The drawings shall show elevations of windows, full size details of frame and vents, details of construction and anchorage of window. All in accordance with actual test methods.

SERIES 4125HD 4" HORIZONTAL ROLLING (AW60 / IMPACT)

Typical Configurations (Scale: Half size)

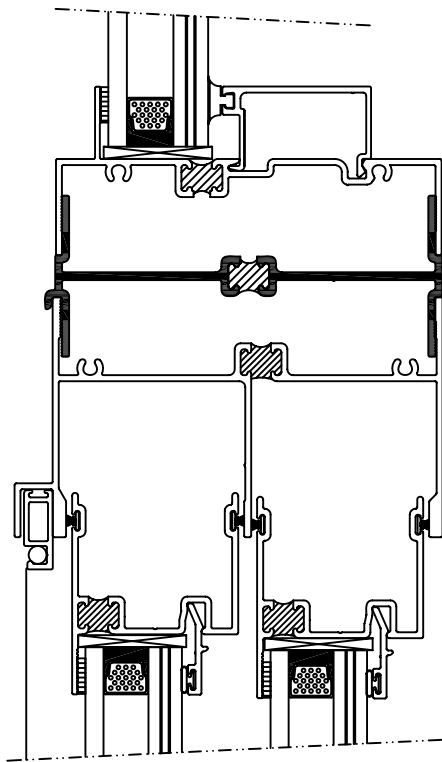

Ⓐ 4125-4150

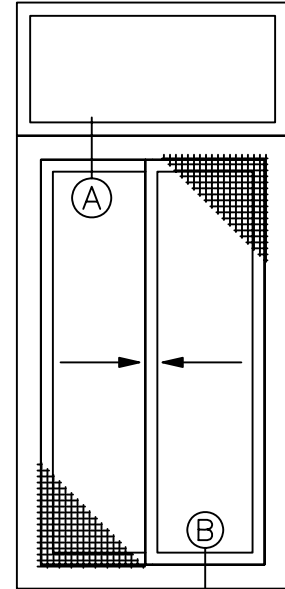

4125-4150

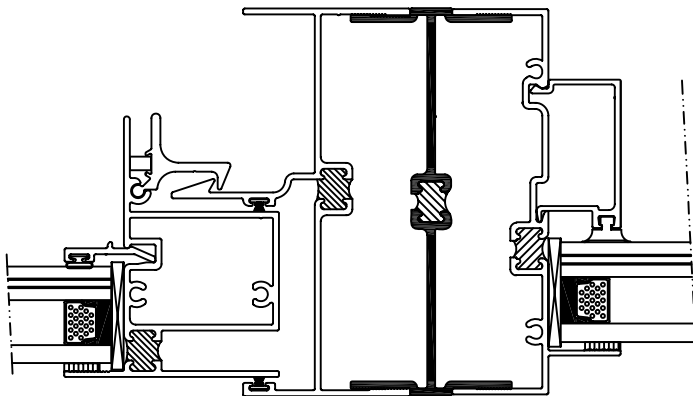

Ⓑ 4125-4150

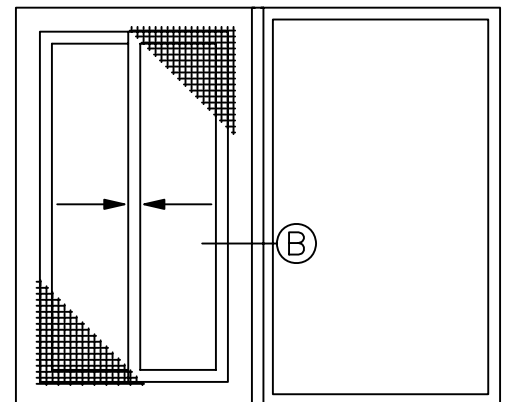

4125-4150

See Accessories section for additional options

SERIES 4125HD 4" HORIZONTAL ROLLING (AW60 / IMPACT)

Product Details (Scale: Half size)

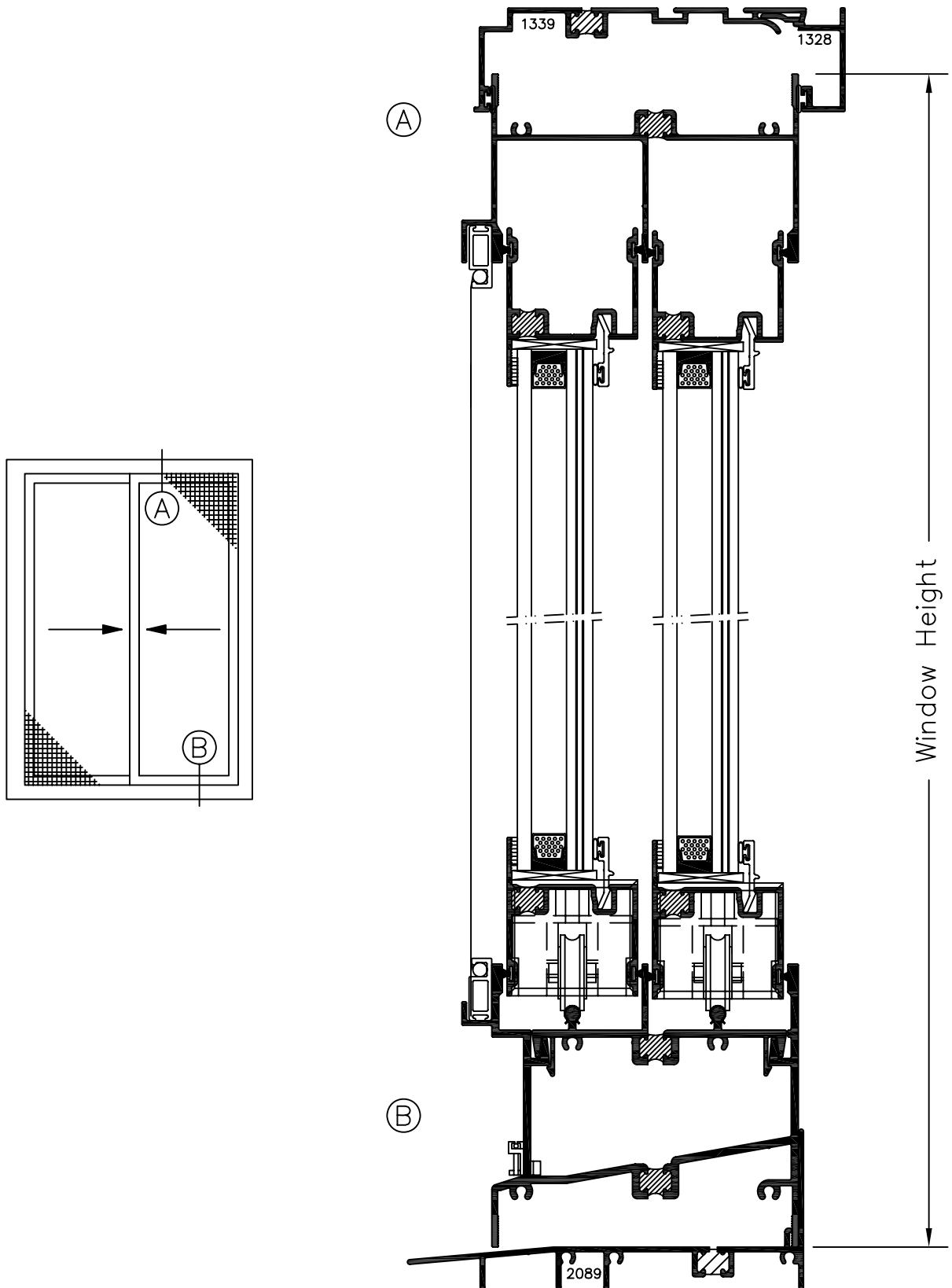

SERIES 4125HD 4" HORIZONTAL ROLLING (AW60 / IMPACT)

Product Details (Scale: Half size)

